

## Modern Technique of MATLAB Based Traffic Management

Sampa M. Barman<sup>1</sup>, Abhijit A. Dutta<sup>2</sup>

<sup>1</sup>(Deptt.of Electronics Engg. P JLCE, Nagpur/RTMNU, India)

<sup>2</sup>(Deptt.of Electrical Engg. DBACER, Nagpur/ RTMNU, India)

**Abstract :-** Over speed is a major factor causing road traffic accidents in the world. Since the early 1980's researchers have developed various algorithms to extract speed information from traffic image sequences. According to the road traffic accidents statistics yearbook published by traffic management bureau, the number of death in traffic accidents due to over speed accounted about 15.7% of total death in traffic accidents in 2008. To reduce the traffic accidents in the world, we are presenting an arrangement in this paper which is given below. Computerized road traffic monitoring system consist of four main modules: Lane detection, determination of flow of traffic in each lane, speed measurement, VLP (vehicle license plate) recognition, informing users on exceeding speed. This report presents the algorithm for lane detection on the highway and after detecting lane vehicle speed measurement will be the function and if any vehicle is exceeding speed it will capture the image of vehicle license plate and finally informing the user. An algorithm is proposed to evaluate the speed of the vehicle by videos; the frame difference method is employed to capture the speed. VLP recognition is an effective form of AVI (automatic vehicle identification) system.

**Keywords: -** Computer vision traffic analysis, image processing, vehicle tracking, speed measurement, motion detection, contour extraction, character segmentation filtration, GSM modem.

### I. INTRODUCTION

Computerized road traffic monitoring system refers to computerized technology that improves transport outcomes such as transport safety, transport productivity, travel reliability, informed travel choices and establishing communication with vehicles in emergency. This project is an approach for reducing road traffic accidents by limiting the vehicle speed including the information of lane marks identification, traffic weight in each lane and informing the users for penalty using GSM technology on exceeding the vehicle speed beyond limit. The vehicle identification method requires sets of detectors mounted along the road. In this technique license plate of the vehicle is detected at one location and then detected again further down the road. Travel time and speed are calculated by comparing the time at which a specific vehicle is detected by pairs of sensors. An increasing number of vehicles are equipped with in-vehicle GSM (satellite navigation) system that has two way communications with a traffic data provider. Position readings from these vehicles are used to compute vehicle speed. In the ideal system setup of computerized road traffic monitoring system, a USB camera is mounted over the center of the high way although other camera settings are possible. The pan/zoom/tilt setting should be fixed to retain detection configuration. The behavior of vehicle moving on the road can be calculated by monitoring traffic through slice windows, a detection line and a tracking line as shown in figure below.

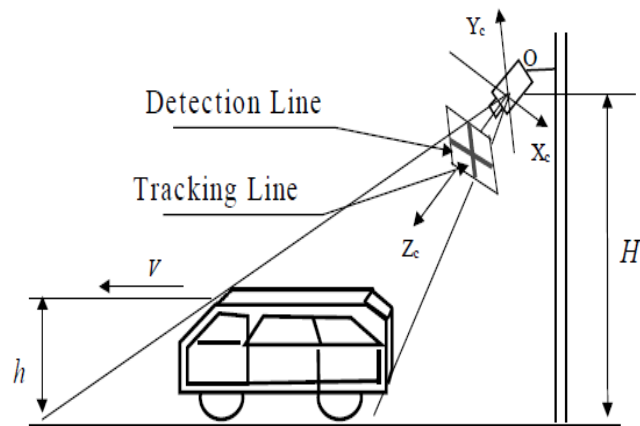

Fig 1: Vehicle lane detection on the road.

As shown in figure (1) above, the camera is calibrated in order to find the relationship between the image coordinates. The edge points of the lane markers are extracted after a image classification process and reconstructed by computer vision in the rigid frame coordinate system. After filtering out the noisy points, the normal vectors of the world coordinate system axis are estimated.

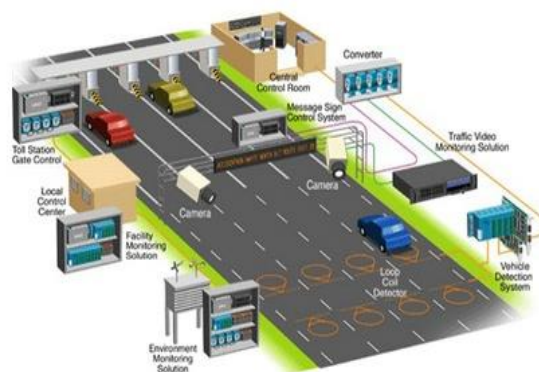

Fig 2: vehicle moving in different lane and practical Camera setup top of the road.

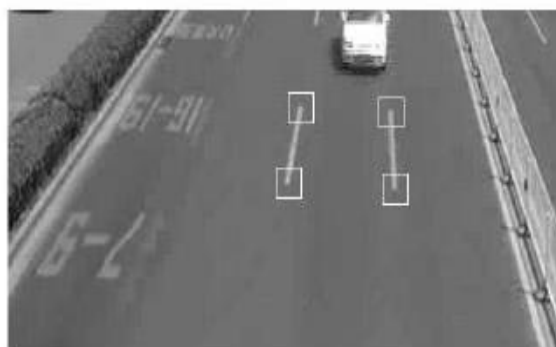

Fig 3: Lane detection

Traffic flow measurement in each lane can be determined with the help of counters and video cameras. The capacity of lane is pre-defined by the traffic providers. Traffic flow measurement using video camera and counters are used for vehicle detection. The detector simply count the number of vehicles during a unit of time. (typically 60 seconds in U.S). video from black and white or color cameras are fed to processor that analyze the changing characteristics of the video image as vehicle pass and detector keeps a count of traffic. Speed of the vehicle can be measured by extracting the frames from the video reading of the car in which it is appearing.

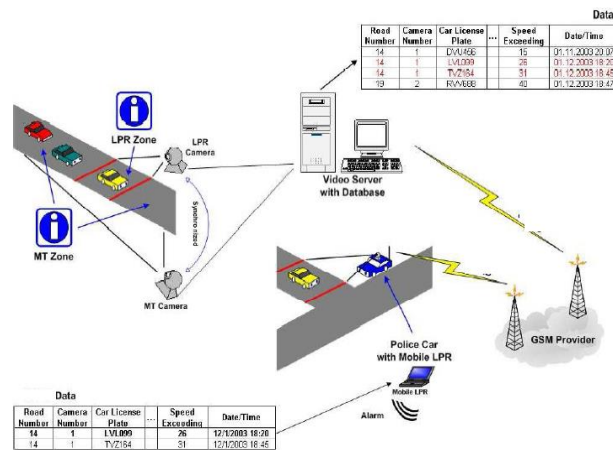

Fig 4: Above figure shows a complete setup of computerized road traffic monitoring system.

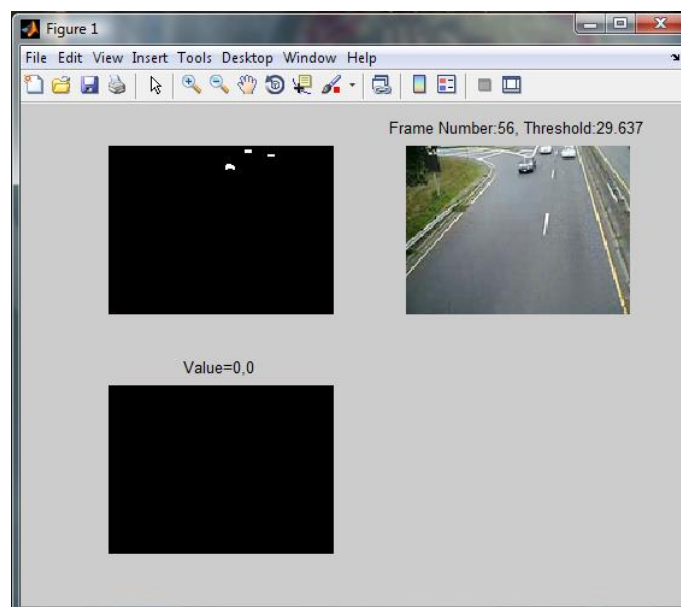

Fig 5: result of lane detection

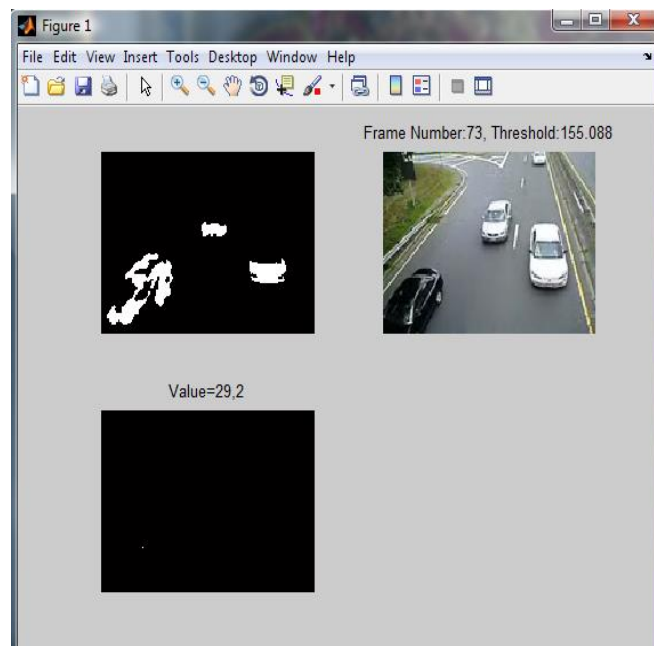

Fig 6: result of lane detection

## II. VEHICLE SPEED MEASUREMENT

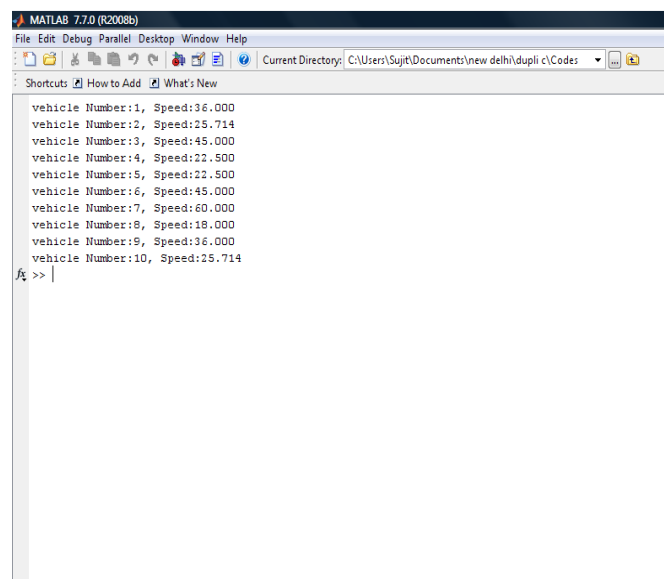

Fig 7: result of speed measurement

### III. APPROACH FOR LICENSE PLATE RECOGNITION USING MATLAB

The implementation of the program for license plate recognition is developed on MATLAB as shown in fig (5). First step is to segment the license plate candidates from the image.

- Horizontal segmentation:

We first do a horizontal segmentation of the image using the histogram method.

- Vertical segmentation:

We first do a horizontal segmentation. After getting the horizontal segments of the candidate region, we would now want to get the vertical co-ordinates in order to extract area from the image .

- Edge density:

Applying the above features to filter the segmented region, a lot of non-license plate regions can be removed. The edge density is measured in a region R by averaging the intensities of all edge pixels within the region.

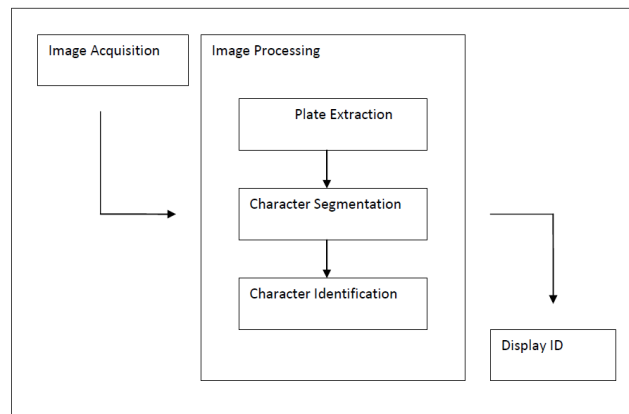

Fig 8: License plate recognition using MATLAB.

### IV. HARDWARE REQUIRED

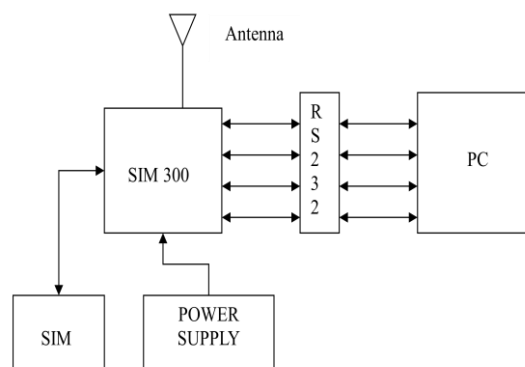

Fig 9: SIM 300

- Designed for global market, SIM300 is a Tri-band GSM/GPRS engine that works on frequencies EGSM 900 MHz, DCS 1800 MHz and PCS1900 MHz SIM300 provides GPRS multi-slot and support the GPRS coding schemes CS-1, CS-2, CS-3 and CS-4.
- The physical interface to the mobile application is made through a 60 pins board-to-board connector (ENTERY Company's 1008-G60N-01 R) , which provides all hardware interfaces between the module and customers' board except the RF antenna interface.
- SIM300 provide RF antenna interface with two alternatives: antenna connector and antenna pad. The antenna connector is MURATA MM9329-2700. And customer's antenna can be soldered to the antenna pad.

## V. CONCLUSION

This paper presented an approach of road traffic monitoring system for reducing the accidents on the high way with lane identification, traffic flow measurement, vehicle speed measurement with license plate recognition and finally informing user on exceeding the speed which is an efficient and helpful technique for reducing the accidents. On the high way 80% of accidents are occurring due to over speed so the proposed system can control the traffic flow accurately with limiting the vehicle speed and meet the precision demand.

## REFERENCES

- [1] Vehicle speed measurement and accident scene investigation-2010 IEEE. Huachun Tan, Jie Zhang, Jianshuai Feng ,Dept. Transportation Engineering, Beijing Institute of Technology Beijing, China.
- [2] Licence plate no. recognition - César Garc'ia-Osorio, José-Francisco Díez-Pastor *Higher Polytechnic School, University of Burgos, Avda. Cantabr'ia, Burgos, Spain* cgosorio@ubu.es, [jdpo014@alu.ubu.es](mailto:jdpo014@alu.ubu.es)
- [3] Automatic vehicle license plate detection-sept 2010IEEE Deepak Kumar Gupta-Y6154 Siddhartha Kandoi-Y6472 CS 676: Image Processing and Computer Vision 2009-10 Semester 1.
- [4] Image processing in road traffic analysis- World Academy of Science, Engineering and Technology 2005 Serkan Ozbay, and Ergun Ercelebi.
- [5] Jianping Wu, Zhaobin Liu, Jinxiang Li. An algorithm for automatic vehicle speed detection using video camara ICCSE. 2009:193-6.
- [6] G.D. Sullivan, K. Baker, et al. Model-based Vehicle Detection and Classification using Orthographic Approximations, in: *Proc. British Machine Vision Association Conference*, 1996.