

ARDUNIO Based Sequential Batch Process Control System

¹Satyam Bhawankar, ²Yogita Throat, ³Pratima Bhuse, ⁴Amol Arsule

Department of Instrumentation Engineering, Government College of Engineering, Chandrapur, 442201

¹satyambhawankar97@gmail.com, ²yogitathorat23@gmail.com, ³pratimabhuse.pb00@gmail.com,

⁴arsule5@gmail.com

Abstract: The rise of new digital industrial technology, known as Industry 4.0, is a transformation that makes it possible to gather and analyze data across machines, enabling faster, more flexible, and more efficient processes to produce higher-quality goods at reduced costs. Now a day due to open source, extensible software and hardware ARDUINO is extensively used in industries for controlling sequence of actions of the process since last few years. In this paper, a ARDUINO based sequential batch process control system is presented. The sequence of process flow is decided for controlling the parameters like real time level, temperature and flow. The control logic is developed for level and temperature control loop using ARDUINO platform. For a level control, a simple transistorized level indicator with the help of LDR (Light Dependent Resistor) is designed. Similarly the completed temperature controller loop using RTD (Resistance Temperature Detector) with displaying temperature in Celsius on 16*2 LCD display is developed.

1. INTRODUCTION

ARDUINO is designed to operate in real time environment. Now a day due to open source, extensible software and hardware ARDUINO[1] is extensively used in industries for controlling sequence of actions of the process since last few years[2]. Hence we have decided to develop ARDUINO based sequential batch process control system in our laboratory. The sequence of process flow is decided for controlling the parameters like level, temperature and flow. The brain of the system is ARDUINO. Appropriate hardware for interfacing the process[4] to the controller is developed for controlling the level, temperature and flow of the process. For controlling sequence of actions program is developed. The program minimizes shut down by providing recycle under certain condition to establish normal operation before checking out. Control Box shown in fig.1.2 is same as front panel which includes level indicator, level controller, relay module, LCD Display and controller which deals with process set up showed in fig.1.1. For level control simple combination of transistor and LEDs are used[4]. Intensity of glowed high level led and low level LED absorbed by LDR, hence controlling action[5] is performed. Delay provides precise timings. Finally this system is factory programmable. In order to achieve sequential process control system, sensors are fixed at the field and according to which control actions are performed by controller and cause "ARDUINO based sequential batch process control system".

2. DESIGN OF HARDWARE OF THE SYSTEM.

The basic components of the developed system shown in fig.1.1 are as follows:

- | | |
|-----------------------------------------|-----------------------------------|
| 1) Process tank | 2) ARDUINO UNO |
| 3) Temperature indicator and controller | 4) Level indicator and controller |
| 5) Inlet pump controller | 6) Outlet valve controller |
| 7) Stirrer motor | 8) Power supply section |



Fig.1.1 Experimental Setup



Fig.1.2 Control Box

2.1. PROCESS TANK

For experimental set up, we have used two plastic tank: a) process tank b) storage tank. Storage tank is used for storage of water. Following are the specifications of tanks used as shown in table 1. In the process tank, two level switches are mounted and the distance between the LOW level and HIGH level switch is 220 mm.

2.2. ARDUINO UNO

ARDUINO is sophisticated controller module shown in fig.2 used for controlling various operation of the process. ARDUINO accepts the signals from the process and according to the programming it gives output to the process as per the requirement as shown in fig. 1.2. The program is developed according to the determined sequence of operations.



Fig.2 ARDUINO UNO

2.3. LEVEL CONTROLLER

The process tank is required to be filled with water to a certain level. Hence it is required to control level in the tank. Tank level controller showed in fig.1.2. Level controller unit consist of the following units:

- a) Transistorized water level indicator(3-BC547 transistor, 3-220 Ohm resistor, 3- LEDs)
- b) LDR
- c) Relay module
- d) Pump

Transistor switches can be used to switch a low voltage DC device (e.g. LED's) ON or OFF by using a transistor in its saturated or cut-off state. A transistor is used for switching operation for opening or closing of a circuit. That's why used NPN transistor for switching LED. Transistorized water level indicator is shown in fig.3. For controlling purpose LDR (Light Dependent Resistor) is used. Light dependent resistors, LDRs, or photo resistors are often used to detect light and change the operation of a circuit dependent upon the light levels. Light dependent resistors, LDRs or photo resistors are often used in circuits where it is necessary to detect the presence or the level of light.

Whenever water level touches leads of base terminals, circuit gets completed due to LED glowing same as high level LED glowing and that intensity sensed by LDR. According to their brightness programming is programmed by programmer.

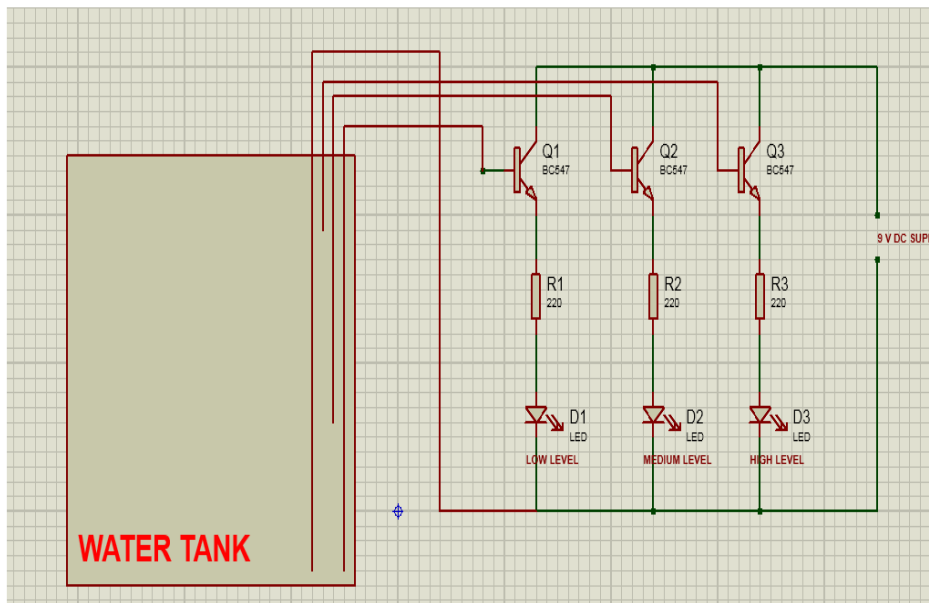

Fig.3. Water Level Indicator

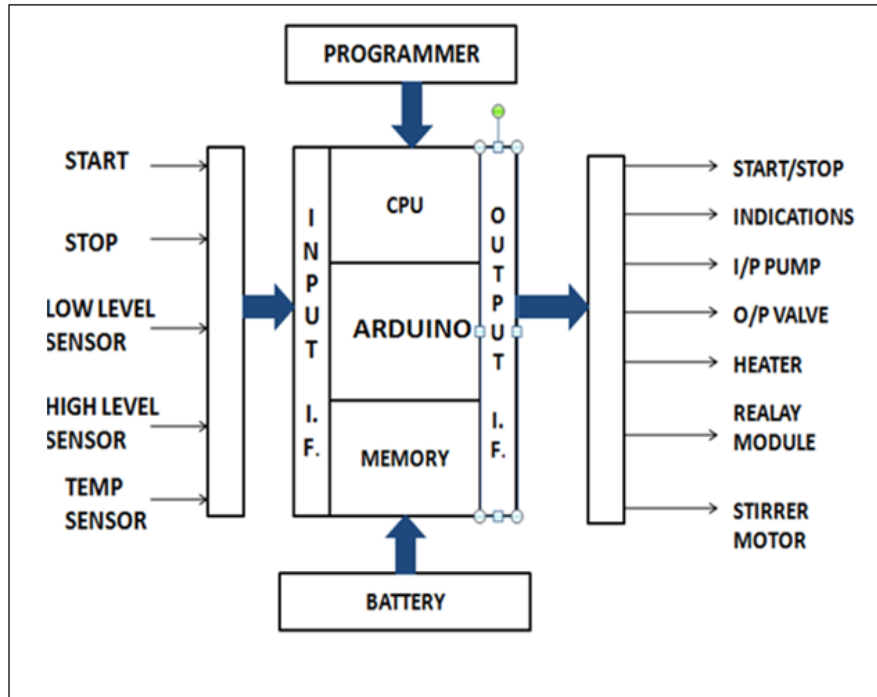

Fig.6. ARDUINO with inputs and outputs

Table.1: Specifications of ARDUINO UNO used

SR no	Parameters	Value
1	Operating Voltage	5V
2	Input Voltage	7-12V
3	Digital I/O Pins	14
4	Analog Input Pins	6
5	DC Current I/O pins	40ma

When LDR sense brightness greater than set point it turns off inlet pump. Position of both high level LED and low level LED is fixed such that LDR can sense easily shown in figure. One black cap is covered on LDR which reduces environmental brightness and only sense LED's brightness. Arrangement of LDR and LED's is shown in fig.4.



Fig.4. Arrangement of LDR& LED's

2.4. Inlet pumpcontroller

Water pump is used as inlet pump to fill the water in process tank. Pump is operated from electromagnetic type of relay of 24 volt DC 1000 ohm that is connected to the output module of ARDUINO.

Table 2: Specifications of Process and Sump tank

Type	Capacity	Height	Thickness
Process	15ltr	30cm	3mm
Storage	20ltr	40cm	3mm

2.5. Stirrer motor controller

After filling the tank with water, it is heated using heater. 24 volt DC motor is used for uniform heating of water. Following are the specifications of the motor. Supply voltage: DC 24V 21000 RPM High Speed Large Torque Motor, Motor Diameter: 42.3 mm. Output shaft diameter: 5 mm. Output shaft length: 10 mm. ARDUINO turns on/off the motor depending on the sequence of program developed by the programmer. When stirrer motor is operated then corresponding LED on the front panel of the control box will glow.

2.6. Temperature Controller

It is required to control the temperature of water in the process time therefore for this experimental setup we have design ON/OFF type of temperature controller.

It consists of following units:

- a) DS18B20 Temperature sensor
- b) Relay circuit
- c) AC 230 Volt heater

DS18B20 is 1-Wire digital temperature sensor from Maxim IC. Reports degrees in Celsius with 9 to 12-bit precision, from -55 to 125 (+/-0.5). Each sensor has a unique 64-Bit Serial number etched into it allows for a huge number of sensors to be used on one data bus.

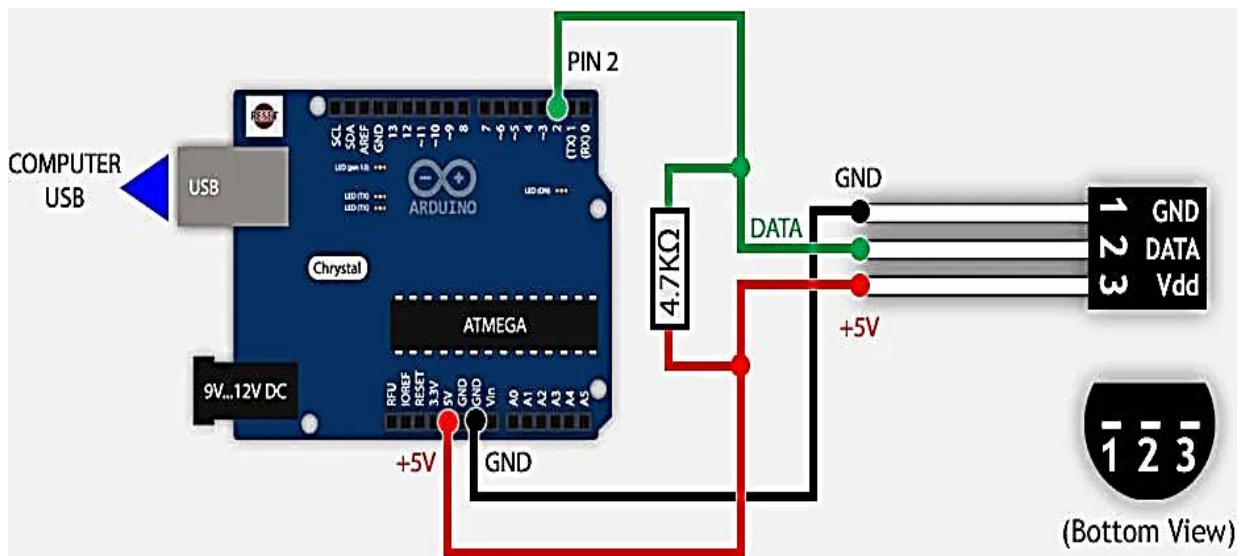

Fig.5. Interfacing of DS18B20 and ARDUINO

To print the data from DS18B20 on the LCD Display build the circuit by following the schematic. First plug the sensor on the breadboard the connect its pins to the ARDUINO using the jumpers in the following order: pin 1 to GND; pin 2 to any digital pin (pin 2 in our case); pin 3 to +5V or +3.3V, at the end put the pull-up resistor, shown in fig.5.

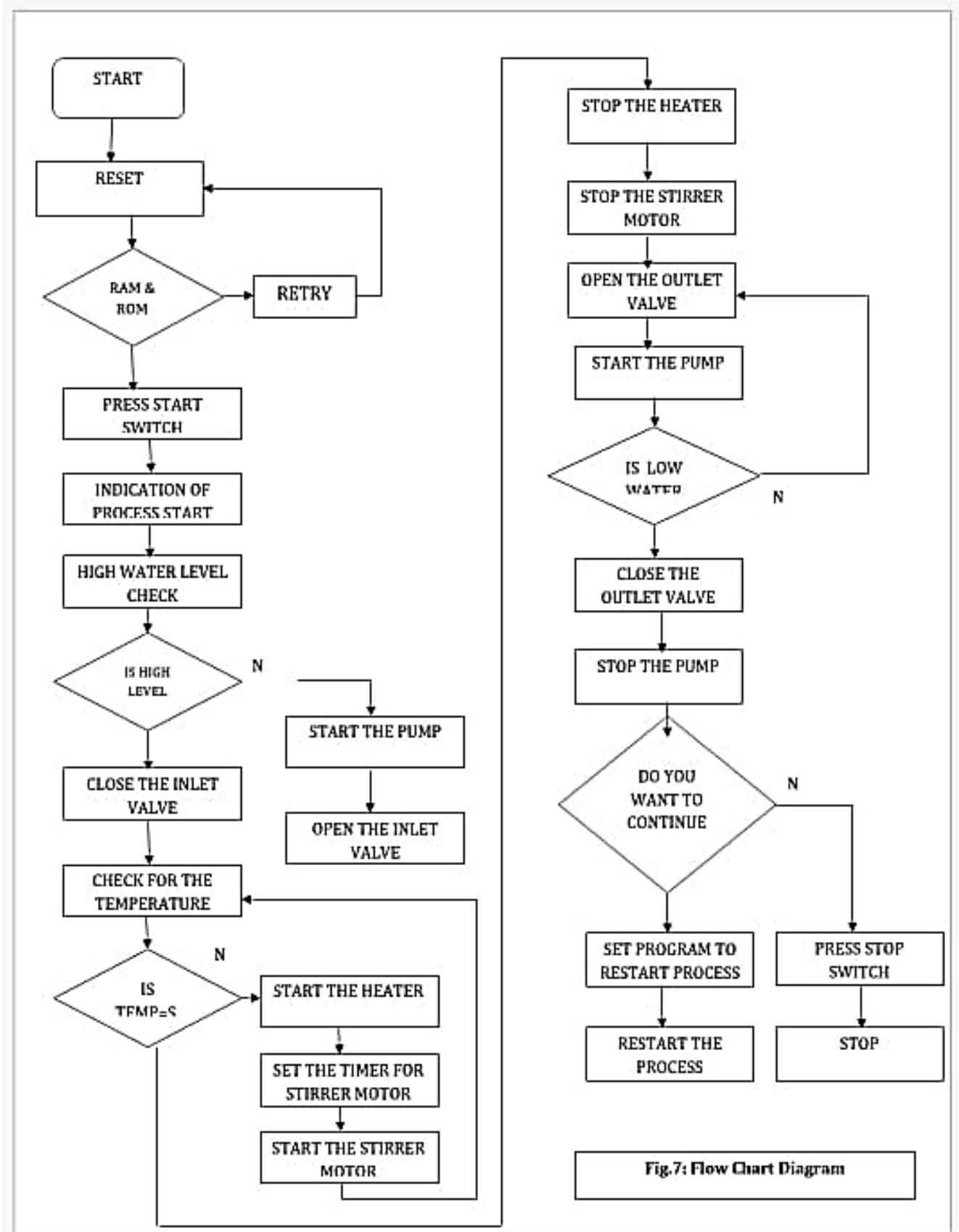

Fig. 7: Flow Chart Diagram

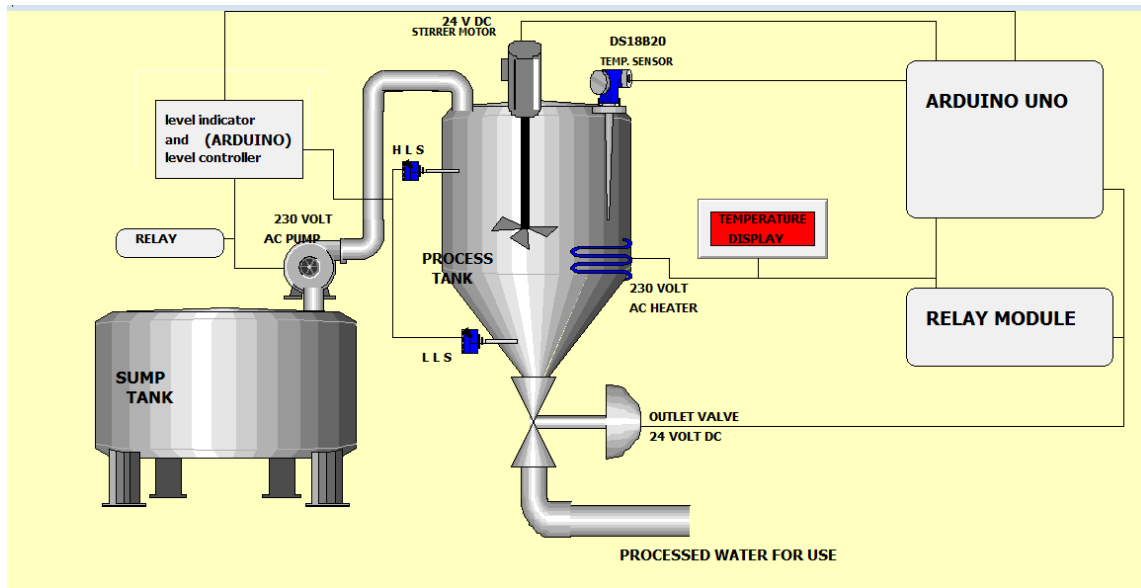

Fig.8. SCADA view of Experimental setup

2.7. Outlet Valve Controller

Solenoid valve is used as outlet valve to drain the water from the process tank when temperature of water reaches to the set point. Solenoid valve is operated from the electromagnetic type of relay of 24 volt DC 1000 ohm that is connected to the output of ARDUINO.

3. DESIGN OF SOFTWARE OF THE SYSTEM

In order to work the philosophy of process control and hardware, we have written appropriate program to provide system operation in sequential manner, in flowchart shown in fig. 7. The whole program is divided into following parts:

3.1. Controller program for level control

ARDUINO checks for the high level, if water level in the tank is below the set point inlet pump is open and outlet valve remains closed. Set point is provided by the programmer while programming. When the water level in the tank reaches up to high level, pump will be turned off, and outlet valve will remain closed. This completes the level control loop.

3.2. Controller program for Temperature control

We have used 230 volt heater to provide heating to the water in the process tank. The temperature set point is provided by programmer while programming. When the water temperature in the process tank is less than that of set point of temperature provided then it would turn ON heater. Heater will be turned OFF when temperature in the process time reaches up to the set point of temperature.

3.3. Controller program for Stirrer motor control

Stirrer motor will be turned ON by ARDUINO for 10 seconds. When heater turned OFF, stirrer motor turned ON so as to provide uniform heating to the water in the process tank.

3.4. Controller program for Outlet valve control

When the batch process of heating of the water is completed then for circulating the water, outlet valve is opened by the ARDUINO.

3.5. Libraries used in program

- 1) One Wire
- 2) Dallas Temperature
- 3) Liquid Crystal

References

1. Vikram Puri, "A review of Arduinoboard's, Lilypad's&Arduino shields",18 March 2016, INSPEC Accession Number: 16426549,IEEE,Conference Location: New Delhi, India.
2. L. N. Liu and J. Hu, "The practice of MATLAB simulation in modern control theory course teaching," in Proc. IEEE Fifth International Conference on Advanced Computational Intelligence, Oct. 18-20, 2012, pp. 896-899.
3. Arduino Website. [Online]. Available: <http://www.arduino.cc/>.
4. R S Sedha, Electronic Measurement and Instrumentation, 1stedition by Chand Publications, ISBN: 9788121997751.
5. Krishna Kant, Computer Based Industrial Control, 2ndedition, **Published** by Prentice Hall Of India **ISBN-10:** 9788120339880.
6. G. Arduino, P. Reggiani, E. Todini. Recent advances in flood forecasting and flood risk assessment. Hydrology and Earth System Sciences Discussions, European Geosciences Union, 2005, 9 (4), pp.280-284. fahal-00304828f.
7. S Visalatchi, K Kamal Sandeep "Smart energy metering and power theft control using arduino & GSM" 7-9 April 2017,DOI: [10.1109/I2CT.2017.8226251](https://doi.org/10.1109/I2CT.2017.8226251), IEEE, Mumbai, India.
8. S R RDhiwaakarPurusotm, Ramesh Rajesh, VineethVijayaraghavan, "Design of Arduino-based communication agent for rural Indian microgrids", 23 May 2014, DOI: [10.1109/ISGT-Asia.2014.6873865](https://doi.org/10.1109/ISGT-Asia.2014.6873865), IEEE, Kuala Lumpur, Malaysia.